

**DETAIL 1**  
 (REF.: S101, S201 & S401)  
 (12 PLACES)

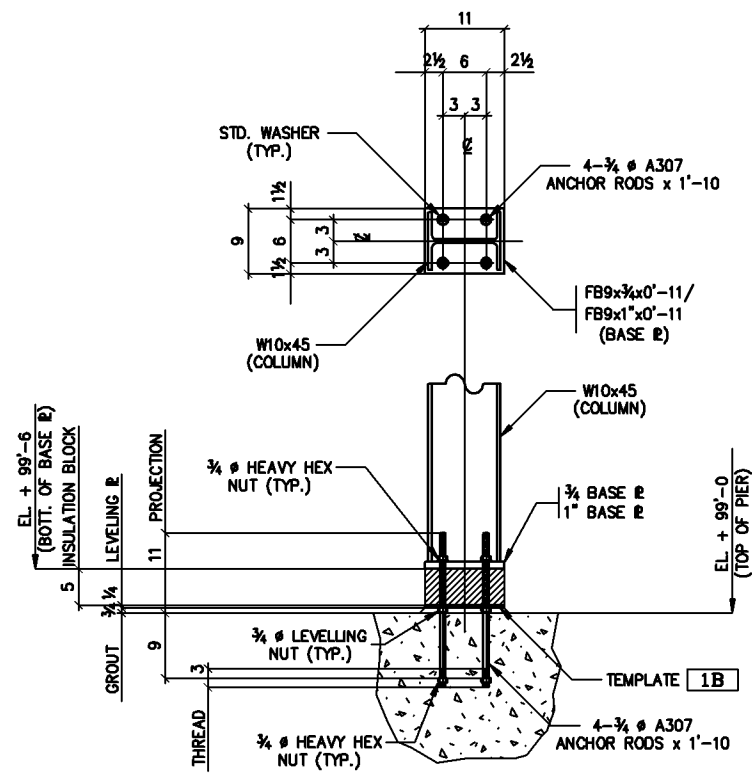

**DETAIL 2**  
 (REF.: S101, S201 & S401)  
 (29 PLACES)

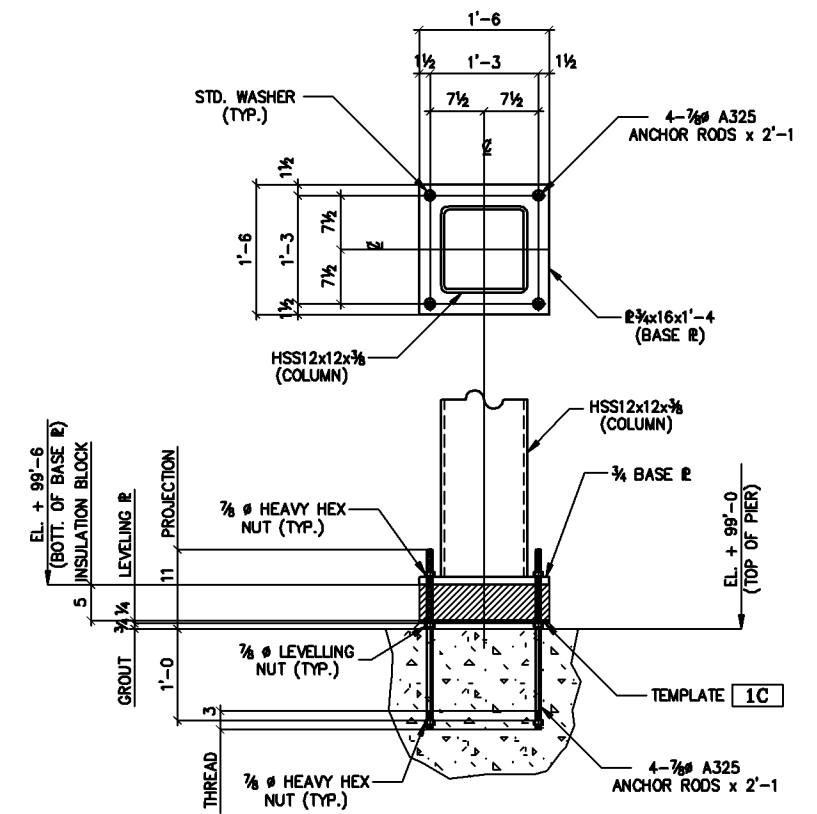

**DETAIL 3**  
 (REF.: S101, S201 & S401)  
 (3 PLACES)

SAMPLE

FOR CONSTRUCTION - 09/28/05  
 FOR APPROVAL - 09/20/05

REVISIONS			PRINT RECORD		
DATE	NO.	BY	NO.	FOR	DATE

Customer _____	Drawn _____	Checked _____
Project _____	By _____	By _____
Arch/Engr _____	Date _____	Date _____
Description _____	or	
JOB NAME _____	JOB# 050253	